

ASSEMBLY INSTRUCTION

MONTGOMERY

BEDSIDE TABLE

ITEM CODE 79251

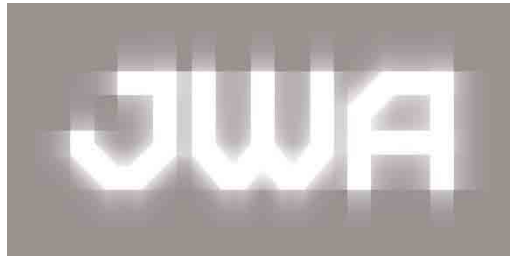
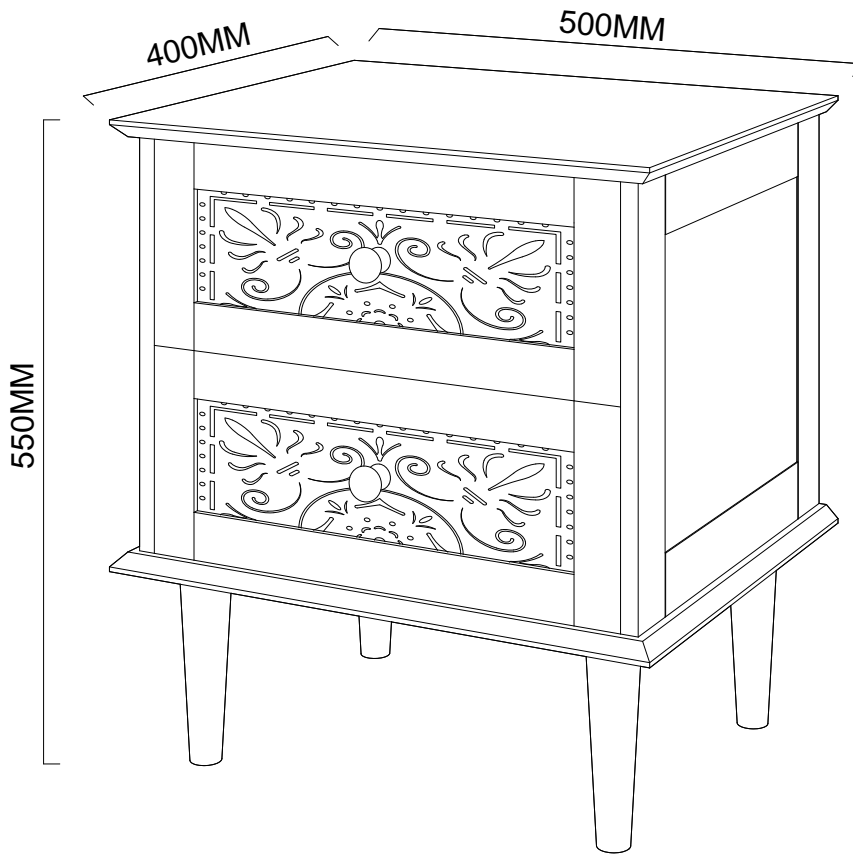

Imported by JWA Furniture Pty Ltd, Qld, Brisbane Australia.
For any assistance with assembly or for missing parts please refer to your receipt

PRE-ASSEMBLY PREPARATION

Before you start:

1. Choose a clean, level, spacious assembly area. Avoid hard surfaces that may damage the product
2. Take care when lifting. Product should be assembled as near as possible to the point of use
3. Ensure that you have all required contents for complete assembly
4. Always read the assembly instructions carefully before beginning assembly.
5. Keep all hardware parts and packaging out of reach of small children.
6. Do not over tighten the screws and bolts as this may damage the threads

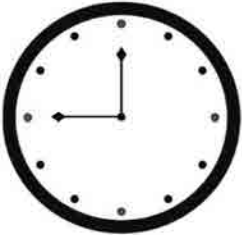
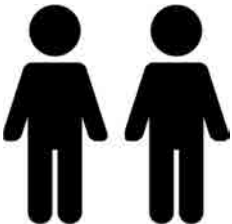
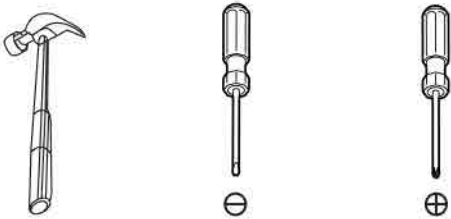
		
Allow 45 min	For 2 person	Additional tools required

TIPPING WARNING



Serious or fatal injuries may occur from furniture toppling over. To help avoid this please follow the below recommendations:

- Install the provided "Tipping Kit" as per the instructions
- Never allow children to climb on or hang off of any part of this product
- Unless specifically designed to accommodate, do not set TVs or other heavy objects on top of this product

If this product has drawers:

- Place the heaviest items in lowest drawers
- Do not open more than 1 drawer at a time as this may cause the product to become unbalanced
- Do not tamper with or remove any drawer interlocking/running system







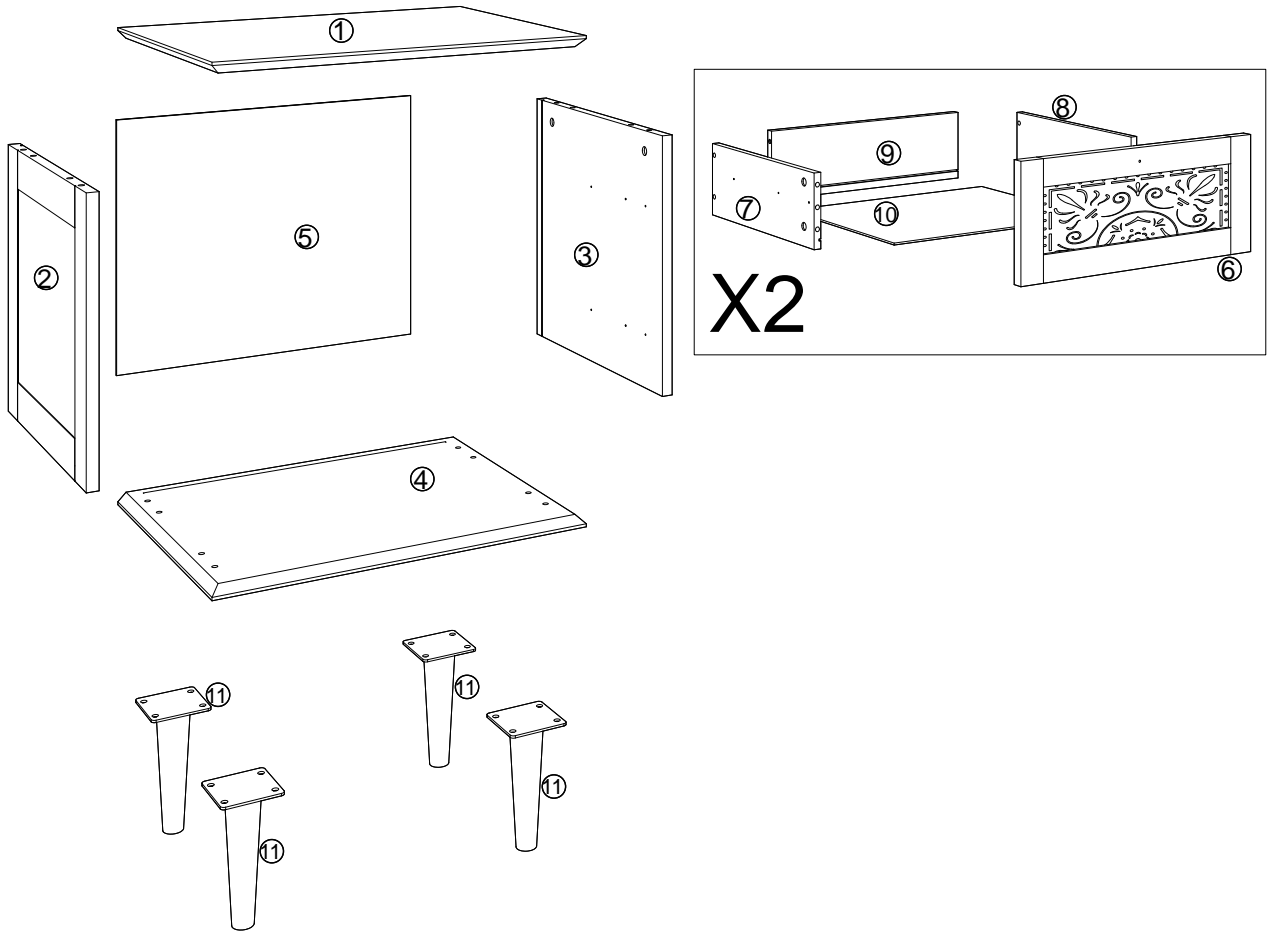

Note: The use of the provided "Tipping Kit" may reduce but not necessarily eliminate the risk of furniture toppling over. Please use this product with caution.

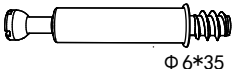
This is a permanent label. Do not attempt to remove!

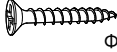
PARTS LIST

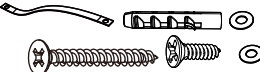
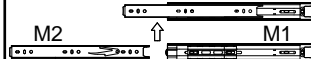
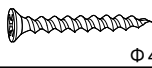

PARTS LIST

NO.	ITEM	QTY	NO.	ITEM	QTY
A	 Φ 6*35	12PCS	I		2PCS
B	 Φ 15*10	12PCS	J	 Φ 4*20	2PCS
C	 Φ 6*30	12PCS	K	 Φ 4*14	16PCS
D	 Φ 4*40	4PCS	L	 Φ 3*12	24PCS
E		1PC	M	 M2 M1	4PCS
F	 Φ 4*35	8PCS			
G		4PCS			
H	 Φ 3*16	4PCS			

↑ Runner Operation

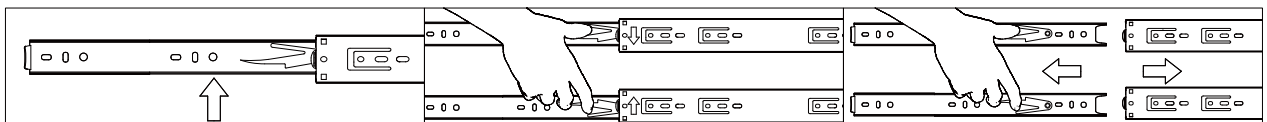

1. Find Switch

2. Push Down or Up

3. Pull out of Runner

PARTS LIST

NO.	ITEM	QTY	NO.	ITEM	QTY
①	TOP PANEL	1 PC	⑦	DRAWER LEFT SIDE PANEL	2 PCS
②	LEFT SIDE PANEL	1 PC	⑧	DRAWER RIGHT SIDE PANEL	2 PCS
③	RIGHT SIDE PANEL	1 PC	⑨	DRAWER BACK PANEL	2 PCS
④	BOTTOM PANEL	1 PC	⑩	DRAWER BOTTOM PANEL	2 PCS
⑤	BACK PANEL	1 PC	⑪	LEG	4 PCS
⑥	DRAWER FRONT PANEL	2 PCS			

STEP 1:

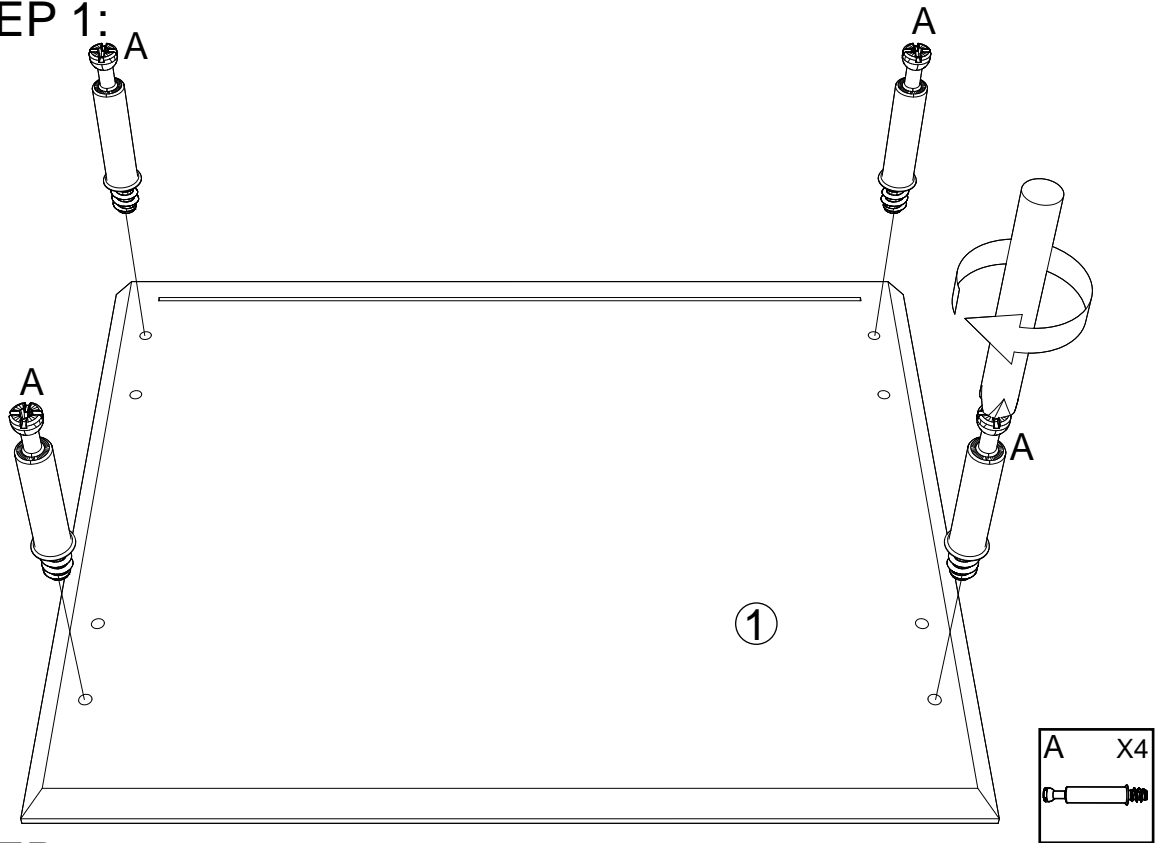

STEP 2:

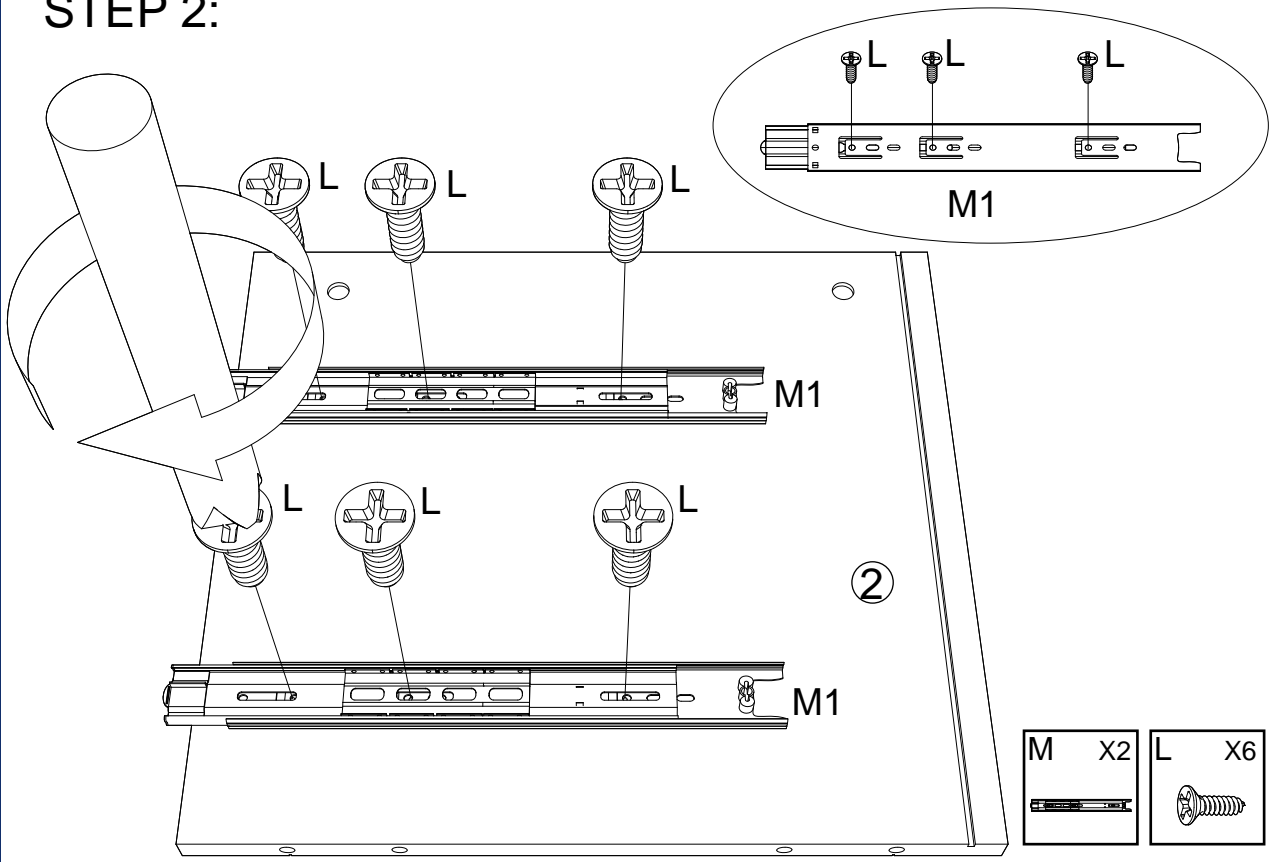

STEP 3:

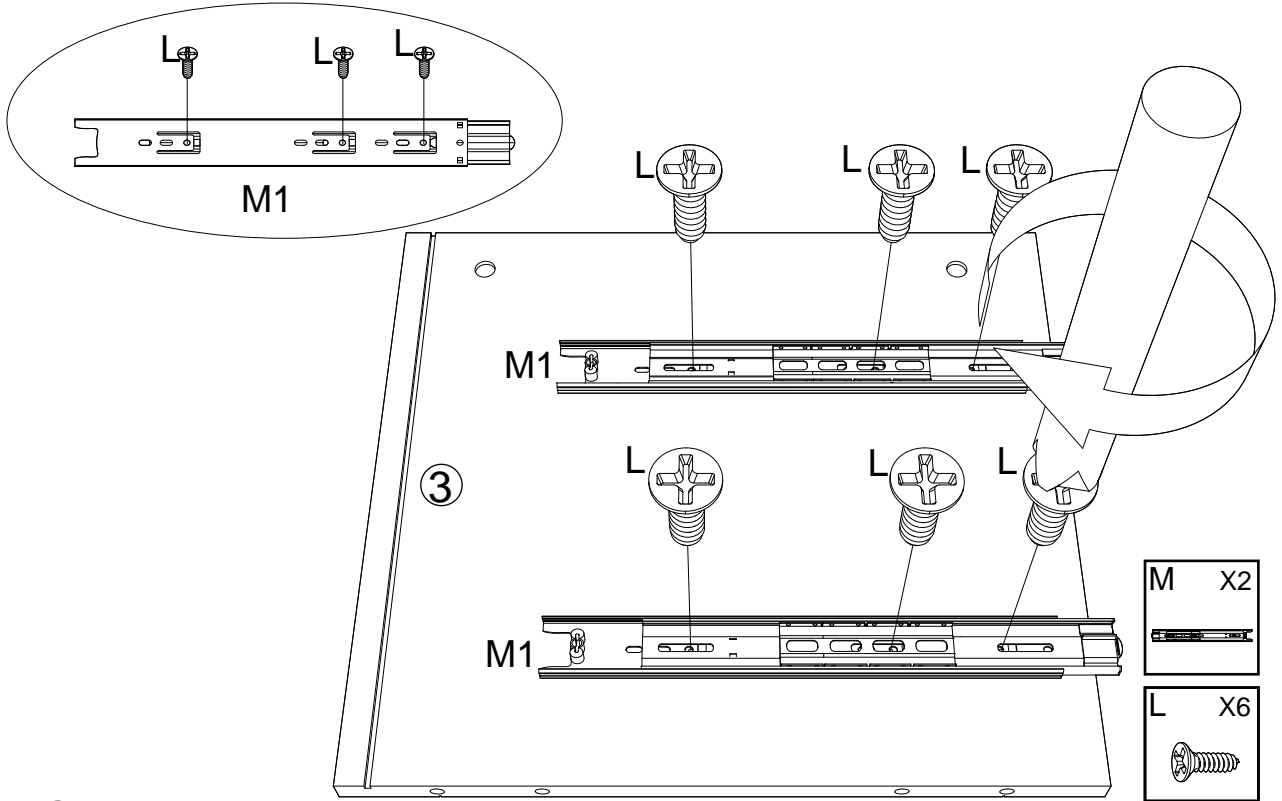

STEP 4:

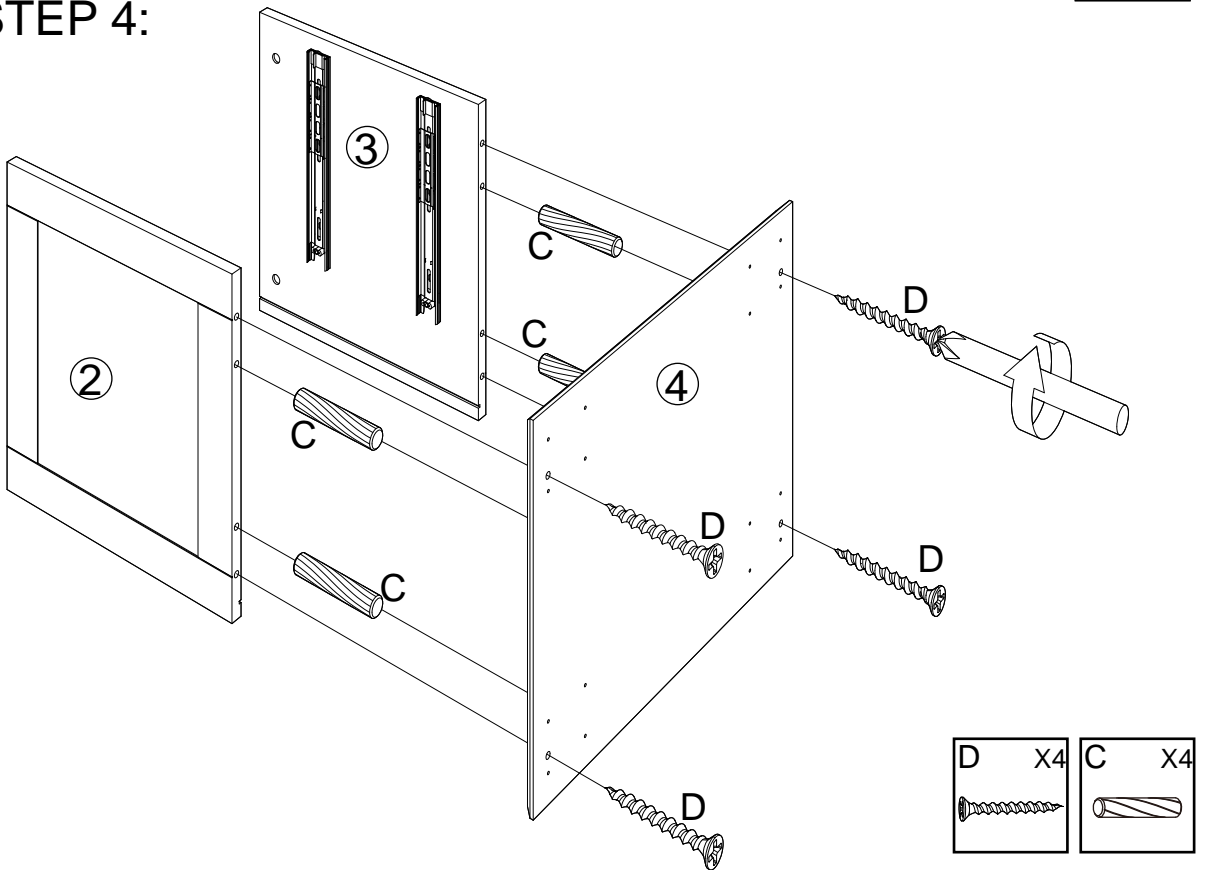

STEP 5:

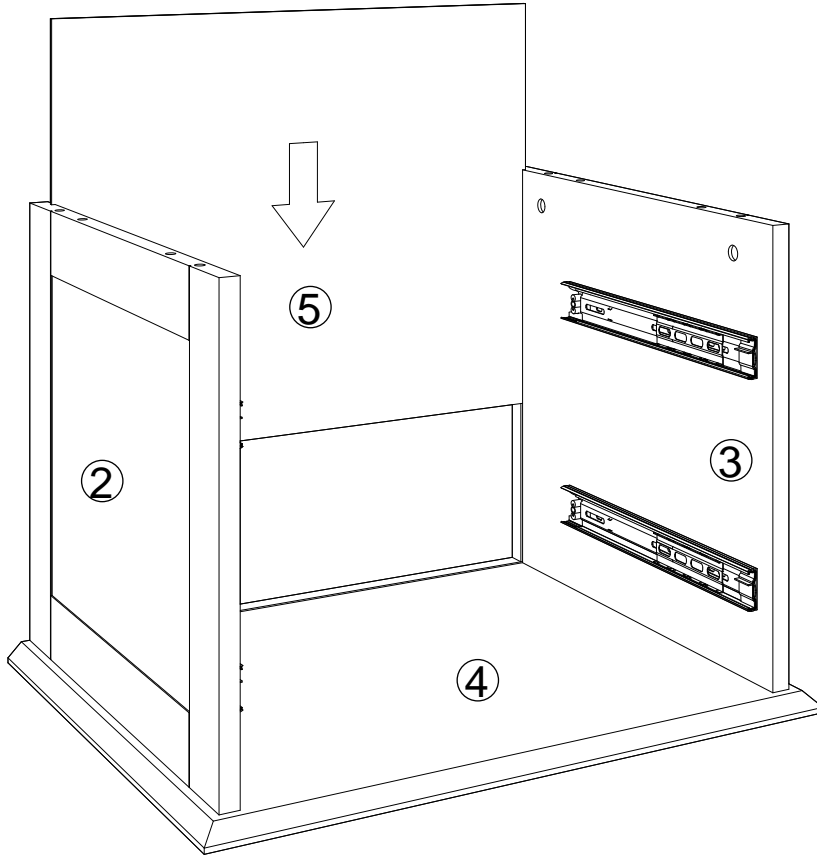

STEP 6:

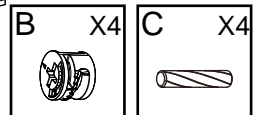
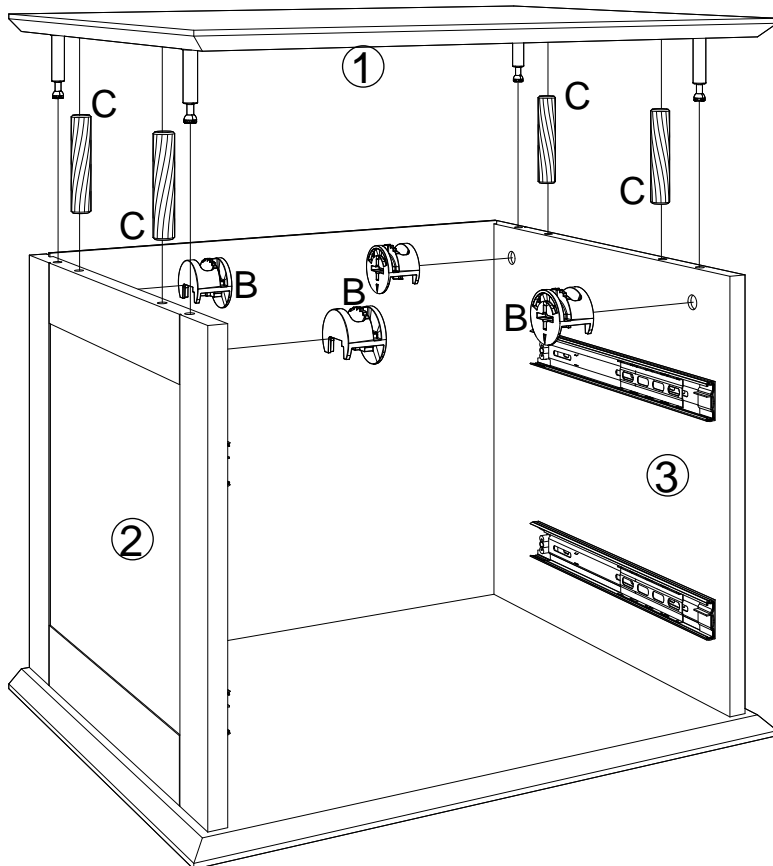

STEP 7:

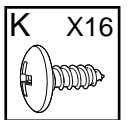
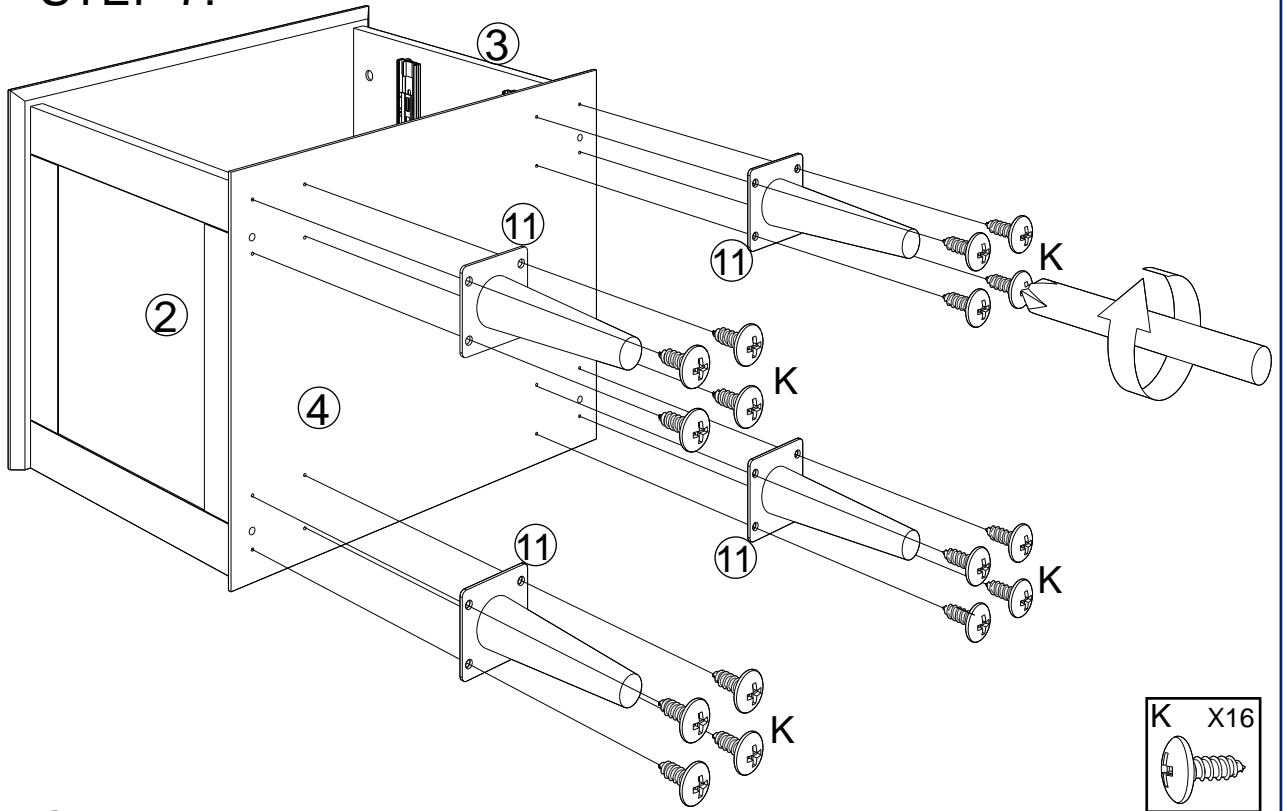

STEP 8:

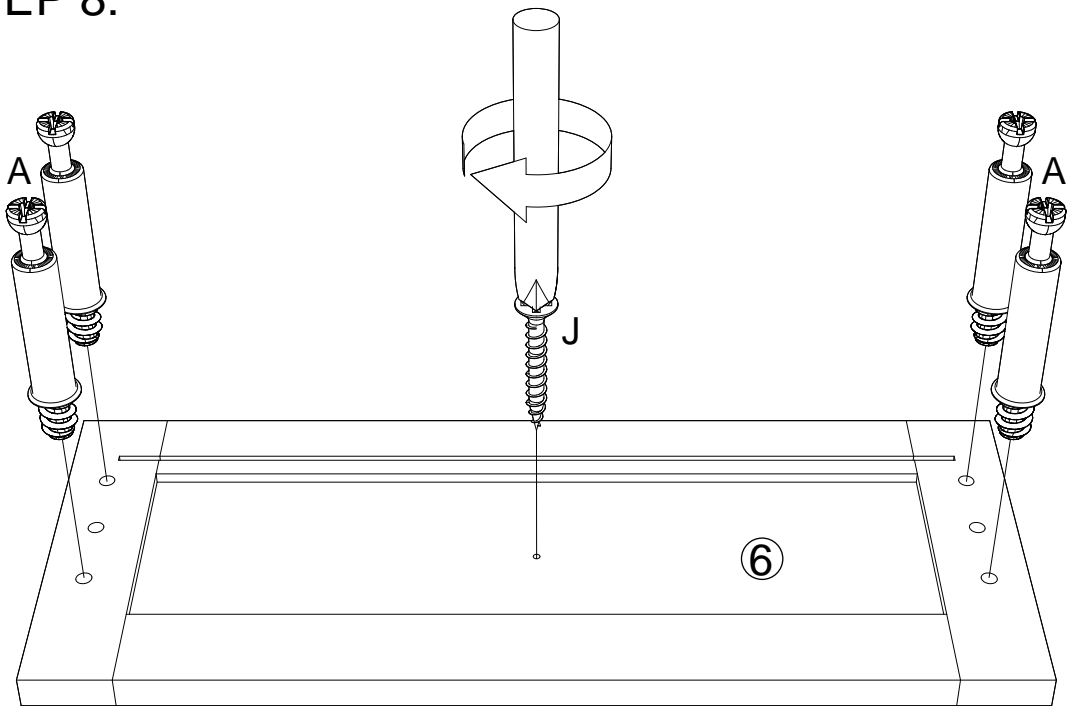

X2

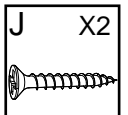
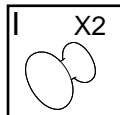
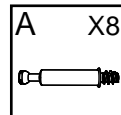
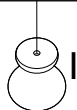

STEP 9:

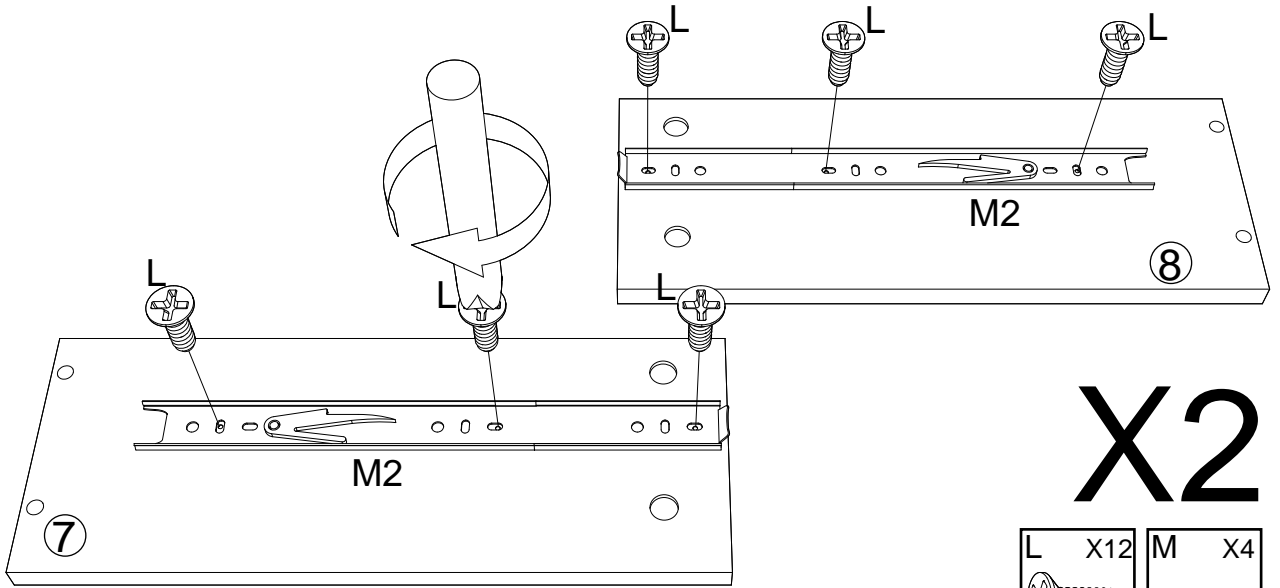

X2

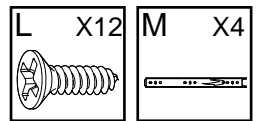

STEP 10:

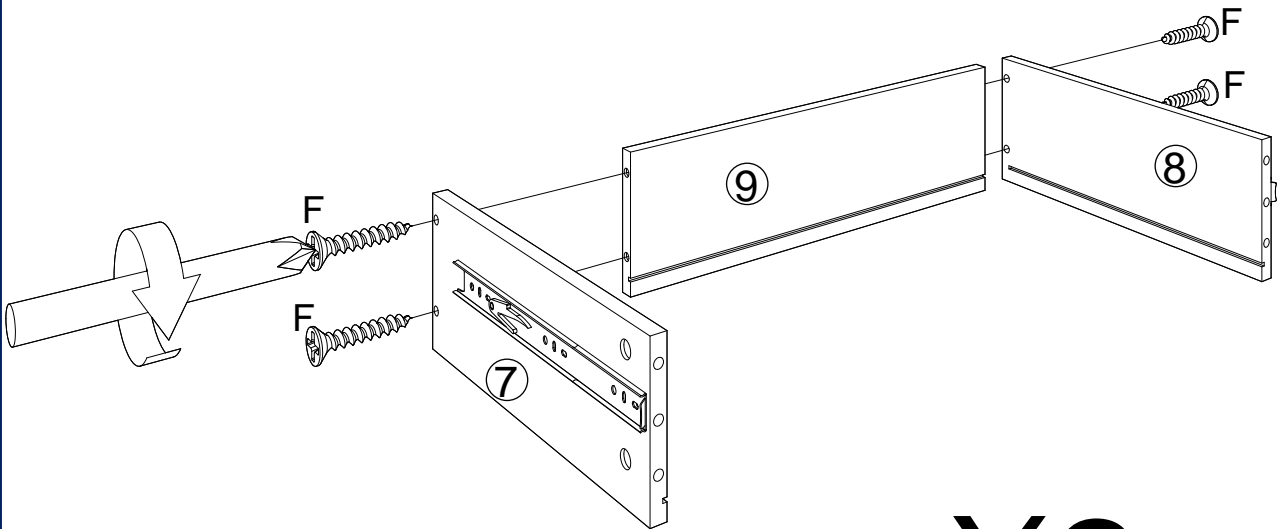

X2

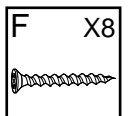

STEP 11:

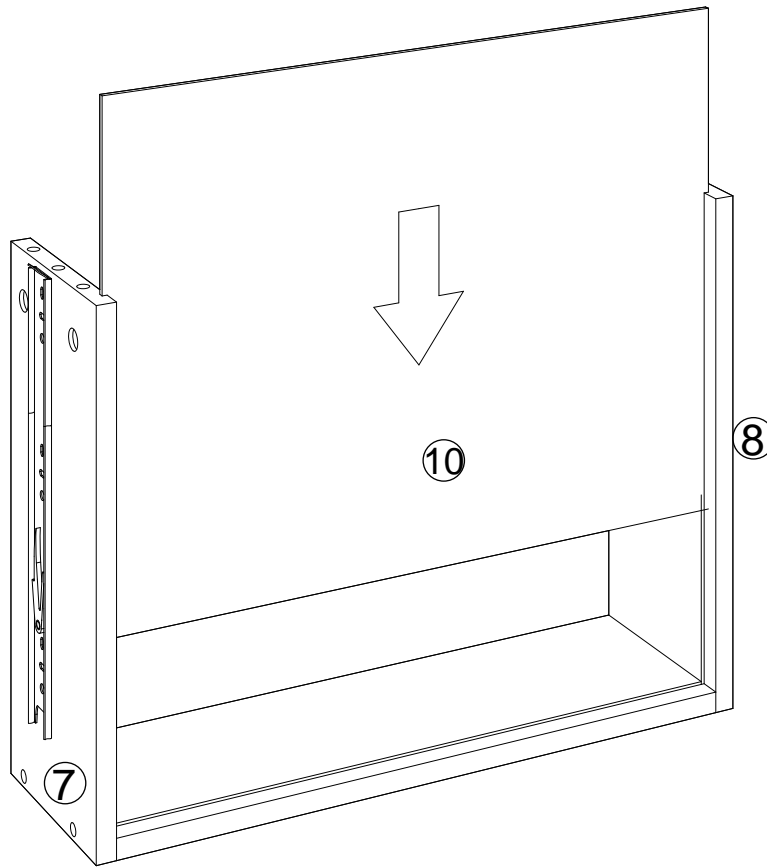

X2

STEP 12:

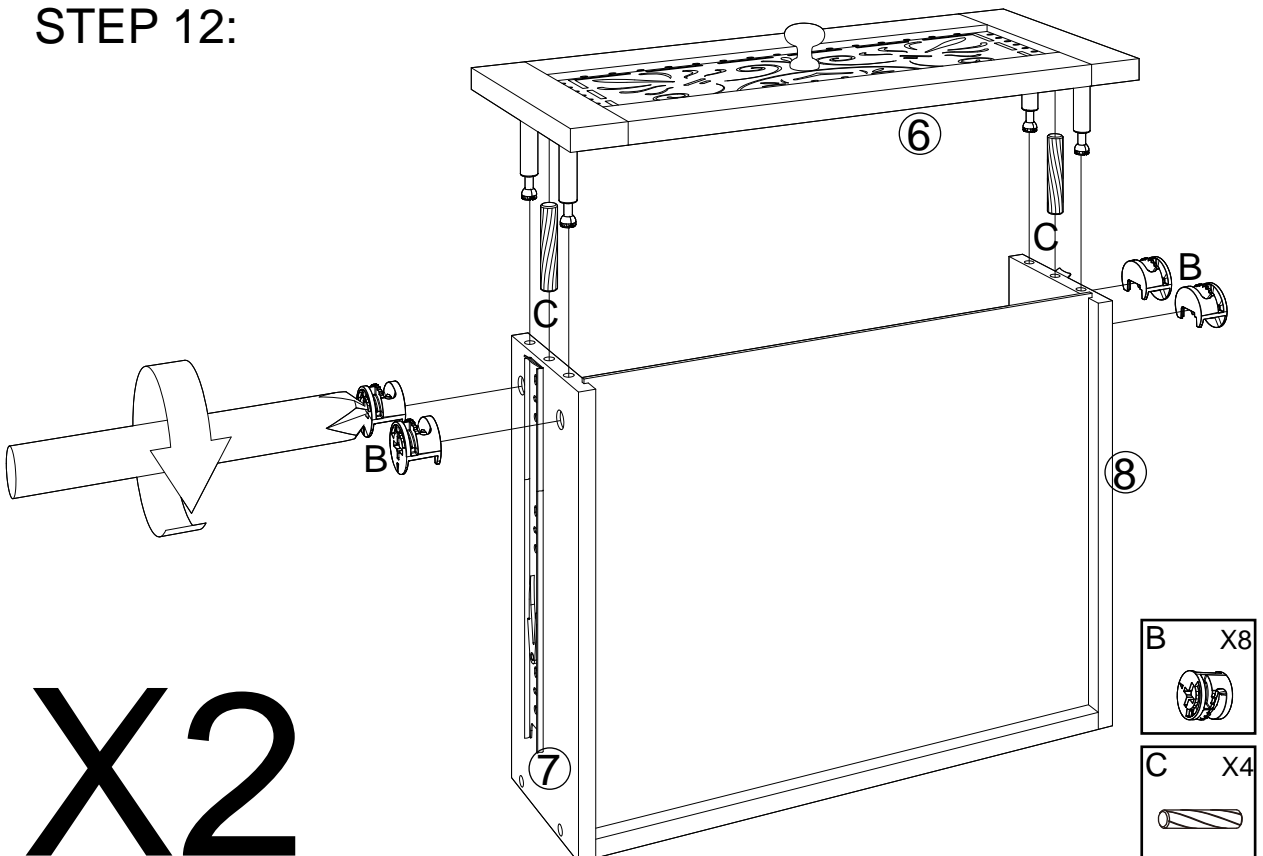

X2

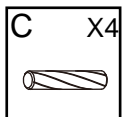
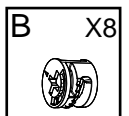

STEP 13:

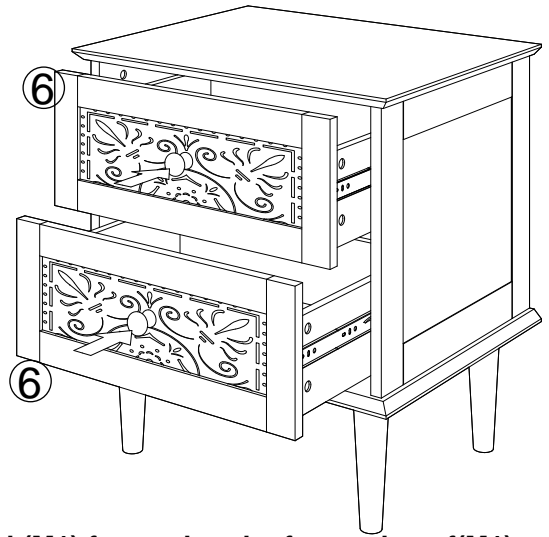
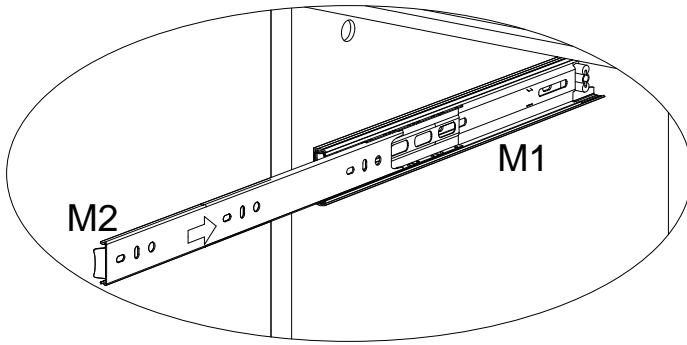

To insert Drawers:

- a) Bring the ball-bearing slider on Drawer Glide Track(M1) forward to the front edge of(M1).
- b) Align the back open-end of the Drawer Glide Runner(M2) on each side of the drawer to fit squarely into the groove on the open front-end of(M1). Be sure the drawer/M2 is not tilted or angled, and gently push in drawer squarely.
- c) When the drawer is pushed in about half way, the Disconnect Lever on (M2) will be engaged onto(M1) which will create a slight resistance-this is normal. Pull out the drawer a little bit and gently push in the drawer again to engage the Lever to the slide mechanism on (M1). The drawer should now slide smoothly.
- d) If the drawer cannot be pushed in or stuck, do not force it in. Remove the drawer and repeat the steps above.

STEP 14:

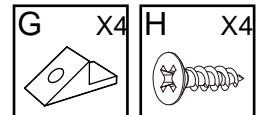
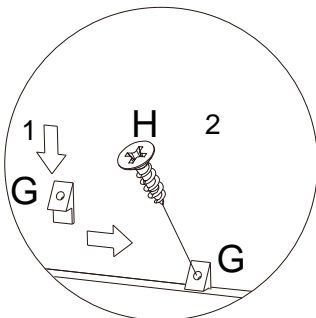
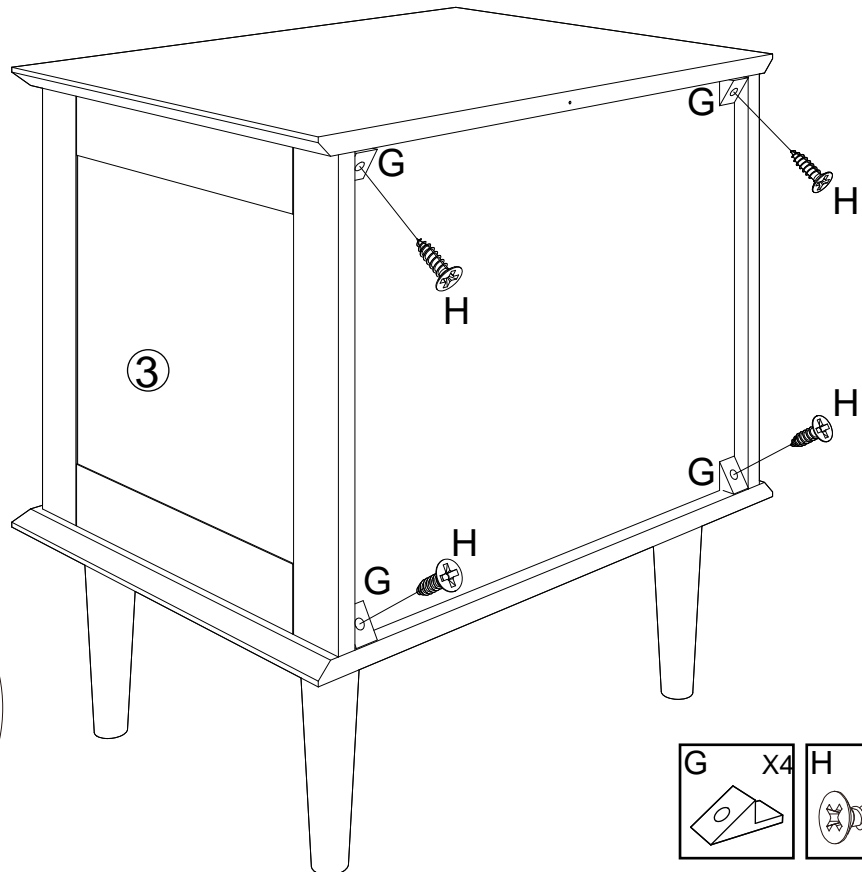

STEP 15: WALL

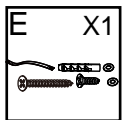
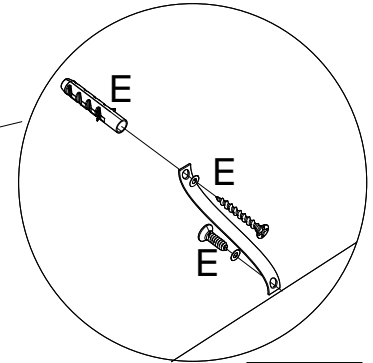
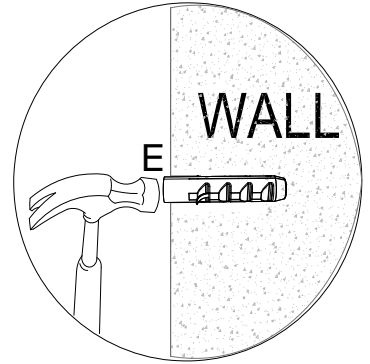
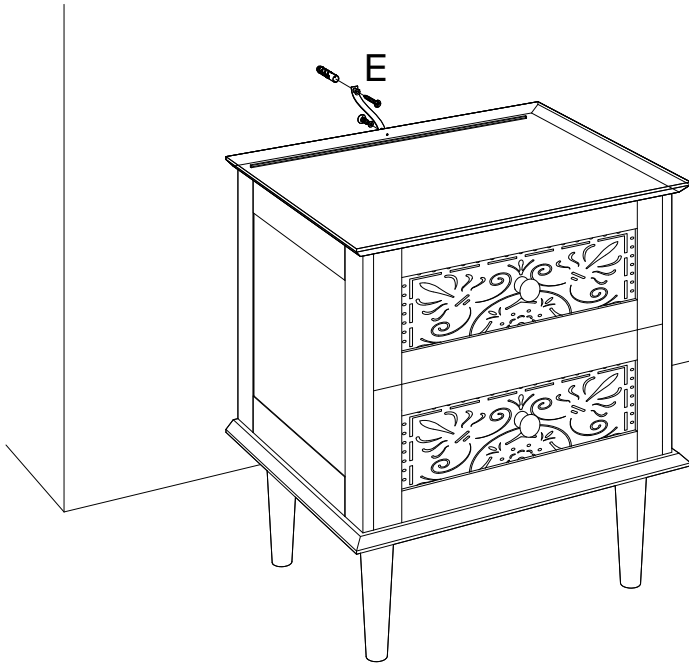

ASSEMBLY IS COMPLETE



CAUTION: Always Lift Your Furniture When Moving /Relocating - Do Not Drag. Dragging Can Cause The Legs To Bend/Break.

SAFETY BRACKETS INSTRUCTIONS

1. Attach the strap to the furniture frame with the small screw and washer.
2. Move the furniture to its final position. Attach the strap to the wall with the large screw and washer. If mounting into brick or masonry you will need to acquire wall anchors.
3. Make sure that the strap is firmly attached to the wall and furniture and that the wall strap is snug.

HARDWARE



Anti-tilt Strap X1



SCREWS X1



SCREWS X1



Expanded plastic pipe X1



washer X2

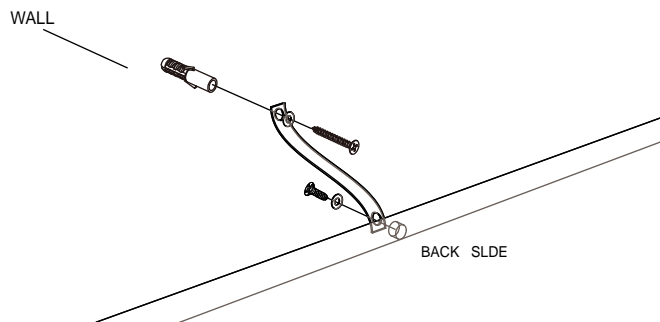

To protect your furniture, we suggest the following:

- Avoid placing your furniture in direct sunlight.
- Do not place furniture directly under windows.
- Do not place sharp materials (knife, fork, etc.) directly onto your furniture as sharp material may scrape and damage the finish.
- Do not place material with high temperature directly onto the surface of your furniture.
- Clean up spills quickly. Water left over a prolonged period of time may cause damage. Alcohol, perfume, nail polishes, aftershave and some medication may cause severe finish damage if not cleaned immediately.
- Use a clean, soft, dry, lint free absorbent cloth to clean your furniture. Do not use any detergent as they may contain ingredients that may react and damage the finish.

NOTE: If the above care advise is not adhered to your product warranty may become void